

step 1



step 1

② (Motor) fixed on ③ (Motor Holder Top)

step 2

Put ⑥ (Aerofoil Arm) between ③ (Motor Holder Top) and ④ (Motor Holder Bottom), then lock them tightly by screws.

step 2

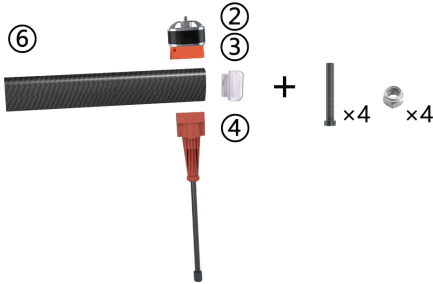

step 3.1

When finished Step2, Put ⑬ (ESC) up above the ⑫ (Main Bottom Plate). The same of the rest ESCs

step 3.2

When finished all the steps up. Put four aerofoil arms in the middle of ⑪ (Main Top Plate) and ⑫ (Main Bottom Plate). Use ⑦ (Joint Top) and ⑧ (Joint Bottom) to connect them.

step 3.1

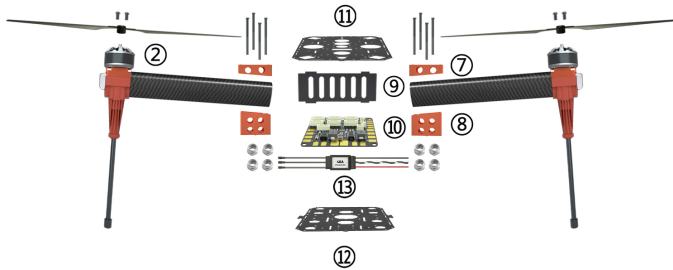

step 3.2

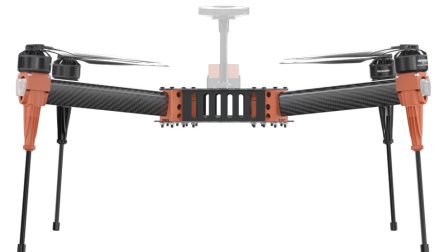
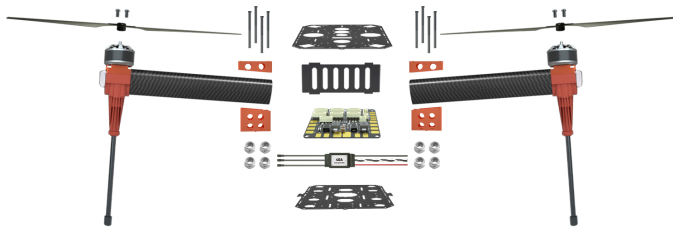

### Part List:

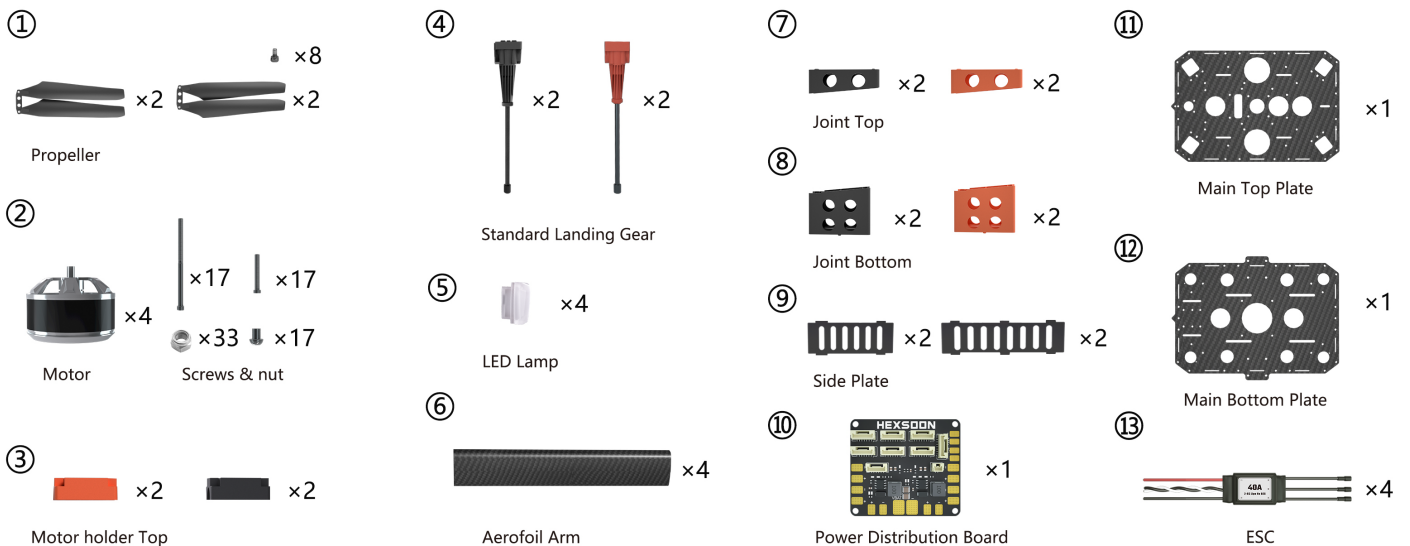

# PDB-40A W/ BEC 5V & 12V

SKU: PDB-40A

The PDB-40A has been engineered to provide the highest possible performance and reliability in a 36\*57mm & 4 layers PCB. It distributes power from a LiPo pack to 6 ESCs, as well as providing Switching Regulator DC 5V outputs & Switching Regulator DC 12V for powering Cameras, Servos, RC receiver, Flight Controllers, Video Transmitters, LEDs, etc.

## Features

- 4oz copper, 4-layers & 1.0mm PCB.
- Total 6 pairs ESC solder tabs are fit for H or X type frame
- 5V & 12V Output LED indicators & Short circuit tolerant

## Specifications

### General:

- Input voltage range (3S-6S LiPo operation): 9 - 26V DC
- Regulated 5V and 12V outputs
- LED power indicators ( 5V & 12V outputs )
- 6 ESC outputs & 1 pair VCC/GND pads

### ESC outputs:

- Peak Current 6x40A
- Continuous current 6x25A

### BEC 5V output:

- Designed for RC Receivers, Flight controllers, OSD, and Servos.
- DC/DC synchronous buck regulator.
- Voltage: 5.3 +/- 0.1VDC
- Continuous current: 3 Amps
- Output Ripple: 40mV (VIN=16V, VOUT=5V@2A load)
- Short-circuit tolerant (5 seconds/minute)
- This connector has the same definition as the cube's carrier board.

### BEC 12V output:

- Designed for Video TX or FPV camera with switching regulator.
- The battery should be 4-6S LiPo (13~26V DC)
- Voltage: 12.0 +/- 0.3VDC
- Continuous current: 2A
- Short-circuit tolerant (2 seconds/minute)

### BEC 12V @ 3S LiPo

- Output voltage= 3S LiPo voltage -1V

### Physical:

- Dimensions: 57.2 x 50.5 x 5.2mm
- Mounting: 52 x 45.3mm, Ø3mm
- Weight: 14.5g(w/o 40A)

## Layout

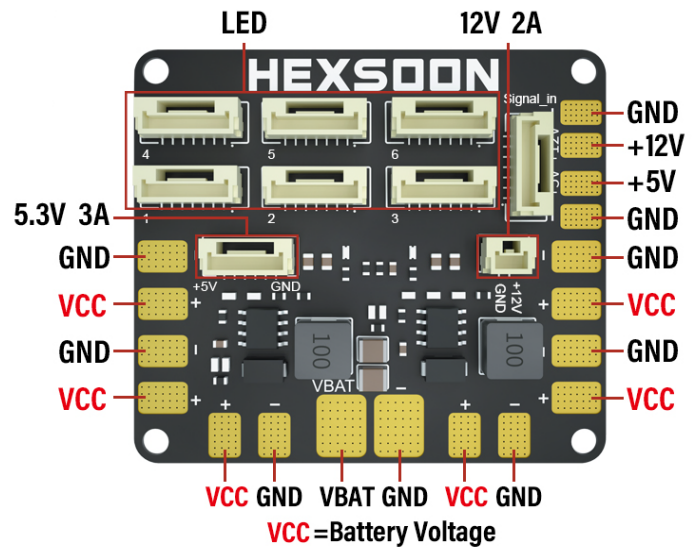

## Connections

